

SUBJECT- PROJECT MANAGEMENT (SEMESTER- 4)

MCQ Question Bank

1. Assembling project team and assigning their responsibilities are done during which phase of a project management?
 - a. Initiation
 - b. Planning
 - c. Execution
 - d. Closure

2. The basic nature of a project is a/an _____ one.
 - a. Permanent
 - b. Temporary
 - c. (A) or (B)
 - d. Both (A) and (B)

3. The process of Control Procurements falls under which process group
 - a. Planning
 - b. Closing
 - c. Monitoring and Control
 - d. Executing s

4. A process that involves continuously improving and detailing a plan as more detail become available is termed as
 - a. project analysis
 - b. project enhancing
 - c. progressive deliberation
 - d. progressive elaboration

5. A program is usually a group of
 - a. plans
 - b. people and work
 - c. related projects
 - d. unrelated projects

6. Which from the following statement(s) is/are NOT true?
 - I. Projects have defined objectives
 - II. Programs have a larger scope than projects
 - III. The projects and programs in a portfolio must be directly related
 - a. I only
 - b. II only
 - c. III only
 - d. II and III only

7. Projects management is divided in _____ process groups.
 - a. 5
 - b. 7
 - c. 9
 - d. 11

8. The scope of the work is defined in which phase of the project management?
 - a. Initiating
 - b. Planning
 - c. Executing
 - d. Closing

9. How the project work will be carried out, monitored, and controlled? These questions are asked in which phase of the project management?
 - a. Initiating
 - b. Planning
 - c. Executing
 - d. Closing

10. The review of the successes and the mistakes is normally held during _____ phase.
 - a. initiation
 - b. planning
 - c. execution
 - d. closure

11. A _____ is a set of activities which are networked in an order and aimed towards achieving the goals of a project.
 - a. Project
 - b. Process
 - c. Project management
 - d. Project cycle

12. Developing a technology is an example of
 - a. Process
 - b. Project
 - c. Scope
 - d. All of the above

13. The project life cycle consists of
 - a. Understanding the scope of the project
 - b. Objectives of the project
 - c. Formulation and planning various activities
 - d. All of the above

14. Following is(are) the responsibility(ies) of the project manager.
 - a. Budgeting and cost control
 - b. Allocating resources
 - c. Tracking project expenditure
 - d. All of the above

15. Design phase consist of
- Input received
 - Output received
 - Both (A) and (B)
 - None of the above
16. Project performance consists of
- Time
 - Cost
 - Quality
 - All of the above
17. Five dimensions that must be managed on a project
- Constraint, Quality, Cost, Schedule, Staff
 - Features, Quality, Cost, Schedule, Staff
 - Features, priority, Cost, Schedule, Staff
 - Features, Quality, Cost, Schedule, customer
18. Resource requirement in project becomes constant while the project is in its _____ progress stage.
- 40 to 55%
 - 55 to 70%
 - 70 to 80%
 - 80 to 95%
19. The probability of completing the project can be estimated based upon the _____ .
- Uniform distribution curve
 - Normal distribution curve.
 - U-shaped distribution curve
 - None of the above
20. In the initial stage of the project the probability of completing the project is ____ .
- Zero
 - High
 - Low
 - Any of the above
21. Each component of the software product is separately estimated and the results aggregated to produce an estimate for the overall job.
- Algorithmic model
 - Expert judgment
 - Bottom-up
 - Top down

22. Devising and maintaining a workable scheme to accomplish the business need” is
- Initiating process
 - Planning process
 - Executing process
 - Controlling process
23. Controlling the changes in the project may affect
- The progress of the project
 - Stage cost
 - Project scope
 - All of the above
24. Following is (are) the tool(s) for changing a process
- Change Management System (CMS)
 - Configuration Management (CM)
 - Both (A) and (B)
 - None of the above
25. Which of these is not one of the constraints of a project?
- Scope
 - Resources
 - Team
 - Budget
26. Which of the following is not correct about initial phase of a project?
- The cost associated at the beginning of the project is highest.
 - Stakeholders have maximum influence during this phase
 - The highest uncertainty is at this stage of the project.
 - All the above statements are correct.
27. The project you are managing has nine stakeholders. How many channels of communications are there between these stakeholders?
- 9
 - 8
 - 45
 - 36
28. A Project with a total funding of \$100,000 finished with a BAC value of \$95,000. What term can BEST describe the difference of \$5,000?
- Cost Variance
 - Management Overhead

- c. Management Contingency Reserve
 - d. Schedule Variance
29. If the Earned Value is equal to Actual Cost, it means:
- a. Project is on budget and on
 - b. Schedule Variance Index is 1
 - c. There is no schedule variance
 - d. There is no cost variance
30. Andrew has joined as the Project Manager of a project. One of the project documents available to Andrew lists down all the risks in a hierarchical fashion. What is this document called?
- a. Risk Management Plan.
 - b. List of risks.
 - c. Monte Carlo diagram.
 - d. Risk Breakdown Structure.
31. During which stage of Risk planning are risks prioritized based on probability and impact?
- a. Identify Risks
 - b. Plan Risk responses
 - c. Perform Qualitative risk analysis
 - d. Perform Quantitative risk analysis s
32. Activity Definition is typically performed by which of the following:
- a. Project Manager who created the WBS
 - b. Project Team Members responsible for the work package
 - c. Project Officer
 - d. Project Stakeholder
33. Which of the following does NOT generate changes to the Project documents?
- a. Define Activities
 - b. Sequence Activities
 - c. Estimate Activity Resources
 - d. Estimate Activity Durations
34. **is** a set of activities which are networked in an order and aimed towards achieving the goals of project?
- a. Project
 - b. Process
 - c. Project management
 - d. Project cycle
35. Developing a technology is an example of

- a. Process
 - b. Project
 - c. Scope
 - d. All of the above
36. Following are the phases of Project Management Life Cycle. Arrange them in correct order
1.Design, 2. Marketing, 3. Analysis and evaluation, 4. Inspection, testing and delivery
- a. 3-2-1-4
 - b. 1-2-3-4
 - c. 2-3-1-4
 - d. 4-3-2-1
37. The entire process of a project may be considered to be made up on number of sub process placed in different stage called the
- a. Technical key resources
 - b. Work key structure
 - c. Work Breakdown Structure (WBS).
 - d. None of the above
38. Which of the option is not a notable challenge while scheduling a project?
- a. Deadlines exist.
 - b. Independent activities.
 - c. Too many workers may be required.
 - d. Costly delay
39. The particular task performance in CPM is known
- a. Dummy
 - b. Event
 - c. Activity
 - d. Contract.
40. The earliest start time rule
- a. Compares the activities starting time for an activity successor.

- b. Compares the activities end time for an activity predecessor.
 - c. Directs when a project can start.
 - d. Regulates when a project must begin.
41. The critical path
- a. Is a path that operates from the starting node to the end node
 - b. Is a mixture of all paths.
 - c. Is the longest path
 - d. Is the shortest path
42. Activities A, B, and C are the immediate predecessors for Y activity. If the earliest finish times for the three activities are 12, 15, and 10, then the earliest start time for Y will be
- a. 10
 - b. 15
 - c. 12
 - d. Cannot be determined
43. Activities P, Q and R instantly follow activity M, and their current start times are 12, 19, and 10. Therefore, the latest finish time for activity M is
- a. 11
 - b. 10
 - c. 18
 - d. Cannot be determined
44. PERT analysis is based on
- a. Optimistic time
 - b. Pessimistic time
 - c. Most likely time
 - d. All the above.
45. While scheduling a project by CPM
- a. project is divided into various activities
 - b. Required time for each activity is established
 - c. sequence of various activities is made according to their importance
 - d. All the above.
46. A project has three independent critical paths A, B and C. To reduce the project length, we have to shorten
- a. The activities of A
 - b. The activities of B
 - c. The activities of C
 - d. The activities of A, B, and C simultaneously.
47. Pick up the correct statement from the following:
- a. Total slack is the difference between its late start and early start times

- b. Total slack is the difference between its late finish and early finish times
 - c. The activities on the critical path have zero total slack
 - d. All the above.
48. Referring the figure state which one of the following statements, is correct:
- a. The initial node of activity b is 2
 - b. The final node of activity b is 3
 - c. The initial nodes of activities b and c are the same
 - d. All the above.
49. In arrow diagram figure of Q. 19.119
- a. Activity b is the immediate successor of the activity a
 - b. Activity a has two successors but no predecessor
 - c. The terminal nodes of activities d and e is 5
 - d. All the above.
50. Frequency distribution curves
- a. having a single lump, are called unimodal curves
 - b. if symmetrical, are called normal curves
 - c. if not symmetrical, are called skew curves
 - d. all the above.
51. The technique for establishing and maintaining priorities among the various jobs of a project, is known
- a. Event flow scheduling technique
 - b. Critical ratio scheduling
 - c. Slotting technique for scheduling
 - d. Short interval scheduling.
52. The PM distributed a document to the stakeholders, which described the software to be developed, the functionality, the users it would serve and the installation timeline. The document was an example of:
- a. Product scope
 - b. Project scope
 - c. A combination of project and product scope
 - d. It was not complete enough to be either a product or a project scope document
53. Each item of the Work Breakdown Structure is assigned a unique identifier. What is the name of this identifier?
- a. Product ID number
 - b. Code of accounts
 - c. Quality inspection identifier
 - d. Project activity code

54. When developing a project's scope statement, which of the following should not be included?
- Project justification.
 - Cost/benefit analysis
 - Project deliverables
 - Measurable objectives
55. Activities A, B, and C are the immediate predecessors for Y activity. If the earliest finish times for the three activities are 12, 15, and 10, then the earliest start time for Y will be
- 10
 - 15
 - 12
 - Cannot be determined
56. Activities P, Q and R instantly follow activity M, and their current start times are 12, 19, and 10. Therefore, the latest finish time for activity M is
- 11
 - 10
 - 18
 - Cannot be determined
57. Pick up the correct statement from the following:
- Programmed Evaluation and Review Technique, is event oriented
 - Programmed Evaluation and Review Technique is not event oriented
 - Critical Path Method is event oriented
 - Critical Path method is event oriented.
58. Critical path method
- is an improvement upon bar chart method
 - provides a realistic approach to daily problems
 - avoids delays which are very common in bar charts
 - All the above.
59. The performance of a specific task in CPM, is known
- Dummy
 - Event
 - Activity
 - Contract.
60. Completion of an activity on CPM network diagram, is generally known
- Event
 - Node
 - Connector
 - All the above.
61. An event is indicated on the network by a number enclosed in
- a circle

- b. a square
 - c. a triangle
 - d. all the above.
62. Pick up the incorrect statement from the following:
- a. An activity of a project is denoted by an arrow on the net work
 - b. The tail of the arrow indicates the start of the activity
 - c. The head of the arrow indicates the end of the activity
 - d. The arrows are drawn to scale from left to right
63. The artificial activity which indicates that an activity following it, cannot be started unless the preceding activity is complete, is known as
- a. event
 - b. free float
 - c. dummy
 - d. constant.
64. A dummy activity
- a. is artificially introduced
 - b. is represented by a dotted line
 - c. does not consume time
 - d. all the above.
65. The estimated time required to perform an activity, is known as
- a. event
 - b. dummy
 - c. duration
 - d. float.
66. If D is the duration, ES and EF are the earliest start and finish, LS and LF are latest start and latest finish time, then the following relation holds good
- a. $EF = ES + D$
 - b. $LS = LF - D$
 - c. $LF = LS + D$
 - d. all the above.
67. The difference between the time available to do a job and the time required to do the job, is known as
- a. event
 - b. float
 - c. duration
 - d. constraint.
68. If TL is the latest allowable event occurrence time, total activity slack(s), is equal to
- a. $LST - EST$
 - b. $LFT - EFT$

- c. TL-EFT
 - d. all the above.
69. The critical activity has
- a. maximum float
 - b. minimum float
 - c. zero float
 - d. none of these.
70. The time by which activity completion time can be delayed without affecting the start of succeeding activities, is known as
- a. duration
 - b. total flat
 - c. free float
 - d. interfering float.
71. For completion of a project, the critical path of the network represents
- a. minimum time
 - b. maximum time
 - c. maximum cost
 - d. minimum cost.
72. Which one of the following represents an activity?
- a. excavation for foundation
 - b. curing of concrete
 - c. setting of question paper
 - d. all the above.
73. Which one of the following represents an event?
- a. concrete cured
 - b. fixing of door
 - c. plastering of walls
 - d. selecting sites
74. Pick up the correct network for the activities of pouring concrete, erection of form work, removal of form work and curing of concrete from the following:
- a. Pouring of Concrete,2. Erection of form work,3. Curing of concrete,4. Removal of form work
 - b. Erection of form work ,2. Pouring of concrete3. Curing of concrete,4. Removal of form work
 - c. Removal of form work 2. Erection of form work3. Pouring of concrete,4. Curing of concrete
 - d. Pouring of concrete2. Curing of concrete 3. Erection of form work 4. Removal of form work.

75. In a certain project an activity C can only be started when activities A and B have been completed, which have no bearing on each other and can be started independently. The correct network for the activities, is
- Activities A and B can be started independently
 - Activity C can be started only on completion of activity A
 - Activity D can be started only on completion of activity
 - all the above
76. In a project logic, four activities M, N, O and P are to be completed before starting activity Q. If the finish times of M, N, O and P are 12-00 hr, 14-00 hr, 15-00 hr. and 17-00 hr. respectively, the earliest event occurrence time for the activity
- 1200 hr.
 - 1400 hr.
 - 1500 hr.
 - 1700 hr.
77. If the total float and duration of an activity are 5 and 10 days respectively, the particular activity can be
- started 5 days later
 - completed 5 days later
 - performed at slower rate in 15 days
 - all the above.
78. Pick up the correct statement from the following :
- The float may be positive, zero or negative
 - If the float is positive and the activity is delayed by a period equal to its total float, the completion of project is not delayed
 - If the float of an activity is negative, delay in its performance is bound to delay the completion of project
 - All the above.
79. Critical path lies along the activities having total float
- positive
 - negative
 - zero
 - same.
80. Critical Path Net Work helps an engineer
- to concentrate his attention on critical activities
 - to divert the resources from non-critical advanced activities to critical activities
 - to be cautious for avoiding any delay in the critical activities to avoid delay of the whole project
 - all the above.

81. The time which results in the least possible construction cost of an activity, is known
- normal time
 - slow time
 - crash time
 - standard time.
82. A critical ratio scheduling
- establishes the relative priorities among various activities on a common basis
 - determines the status of each activity
 - adjusts automatically changes in activity progress
 - none of these.
83. If a is the optimistic time, b is the pessimistic time and m is most likely time of an activity, the expected time of the activity, is
- $a + m + b$
 - $a + 2m + b$
 - $a + 4m + b$
 - $a + 5m + b$
84. A PROJECT is defined as:
- a temporary endeavor undertaken to create any regular product.
 - a combination of human and nonhuman resources pulled together in a temporary organization to achieve a specified purpose.
 - a routine series of tasks directed toward making profit.
 - Any single activity
85. Which of the following is a characteristic of any projects?
- They are simple and routine business activities
 - They do not have a clear goal or set of goals
 - They have unlimited budget, schedule and resources
 - They are customer focused
86. Which processes are included in the Initiating Process Group?
- Scope planning & Scope definition
 - Develop a project charter
 - Develop project management plan
 - Create WBS
87. Under which category of Project Selection models is the "Payback period" categorized?
- Non-Numeric project selection model
 - Theoretical Project selection model
 - Numeric project selection model
 - Classical Project selection model

88. A document that formally authorizes the existence of a project and provides the project manager with the authority to apply organizational resources to project activities is:
- Project Plan
 - Project Report
 - Project Budget
 - Project Charter
89. Under which category of Project Selection models is the "Sacred Cow" categorized?
- Non-Numeric project selection model
 - Theoretical Project selection model
 - Numeric project selection model
 - Classical Project selection model
90. As per the terminologies of Project Management, PMO is abbreviation of:
- Project Management Office
 - People Management Office
 - Project Management Outcomes
 - Project Management Objectives
91. Which are the decisions at the GATE in Stage Gate Process?
- Go, Kill, Hold, Recycle
 - Go, Start, Process, Recycle
 - Hold, Process, Inspect, Recycle
 - Hold, Kill, Inspect, Recycle
92. Which of the following is a Project Management Knowledge area as defined by Project Management Institute (PMI)?
- Project Financial Management
 - Project Personnel Management
 - Project Integration Management
 - Project Purchasing Management
93. The activity "Closure Contract" is a part of:
- Closing Process Group
 - Monitoring and Control Process Group
 - Executing Process Group
 - Planning Process Group
94. The activity "Activity resource estimation" is a part of:
- Closing Process Group

- b. Monitoring and Control Process Group
 - c. Executing Process Group
 - d. Planning Process Group
95. The activity "Acquire project team" is a part of:
- a. Closing Process Group
 - b. Monitoring and Control Process Group
 - c. Executing Process Group
 - d. Planning Process Group
96. The activity "Manage project team" is a part of:
- a. Closing Process Group
 - b. Monitoring and Control Process Group
 - c. Executing Process Group
 - d. Planning Process Group
97. The activity "Contract Administration" is a part of:
- a. Closing Process Group
 - b. Monitoring and Control Process Group
 - c. Executing Process Group
 - d. Planning Process Group
98. Which of the following activity is included in the "Project Integration Management"?
- a. Develop project charter
 - b. Plan Scope Management
 - c. Define Scope
 - d. Collect requirements
99. Which of the following activity is included in the "Project Scope Management"?
- a. Develop project charter
 - b. Collect Requirements
 - c. Define Activities
 - d. Sequence Activities
100. Which of the following activity is included in the "Project Time Management"?
- a. Develop project charter
 - b. Collect Requirements
 - c. Define Activities
 - d. Determine Budget
101. Which of the following activity is included in the "Project Cost Management"?
- a. Develop project charter

- b. Collect Requirements
- c. Define Activities
- d. Determine Budget

102. The activity "Create Work Breakdown Structure (WBS)" is a part of:

- a. Project Scope Management
- b. Project Cost Management
- c. Project Time Management
- d. Project Scope Management

103. In the process to develop the Project Charter, under which category "Enterprise Environmental Factors" are considered?

- a. Inputs
- b. Tools and Techniques
- c. Outputs
- d. Objectives

104. In the Project Network Analysis, the abbreviation "CPM" indicates:

- a. Common Project Method
- b. Critical Path Method
- c. Critical Project Methodology
- d. Casual Project Method

105. The abbreviation "PERT" used in Project Network Analysis stands for:

- a. Project Examination and Rectification Technique
- b. Projects Evaluation for Rapid Testing
- c. Project Evaluation and Review Technique
- d. Programmed Examination and Recognition Technique

106. Any Task or Operation which consumes resources like man hours, time, capital, machine hours etc. is called as:

- a. Event
- b. Activity
- c. Process
- d. Program

107. An Event which represents the start of Multiple Activities is called as:

- a. Simple Event
- b. Burst Event
- c. Merge Event
- d. Critical Event

108. An Activity which must be completed before the start of Another activity is called as:
- Predecessor Activity
 - Successor Activity
 - Dependent Activity
 - Follower Activity

109. In the Given Project Network Diagram, Activity C is _____ of Activity D.

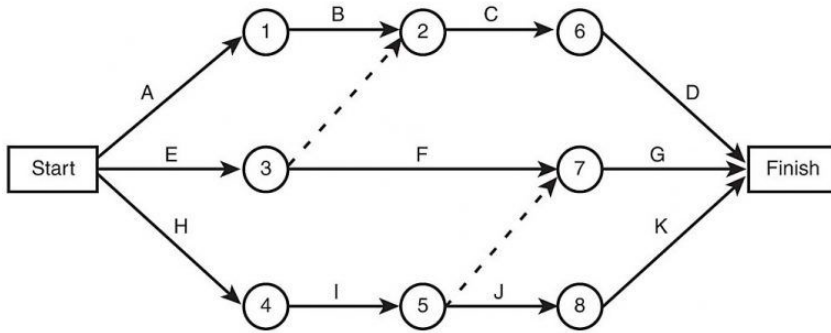

- Predecessor Activity
 - Successor Activity
 - Dependent Activity
 - Follower Activity
110. Observing the Given Project Network Diagram, Select the correct Statement.

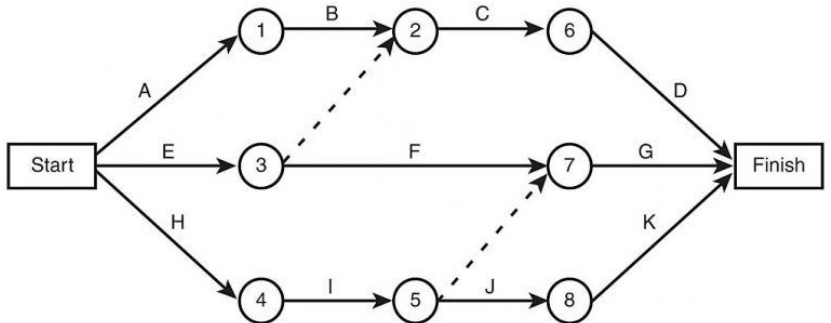

- Activity connecting Node 3 and Node 2 is a Dummy activity.
- Activity B is Predecessor activity for Activity A
- Activity connecting Node 3 and Node 7 is a Dummy activity.
- There are 4 Dummy activities involved in the Network diagram.

111. In the Given Project Network Diagram, Identify the Successor Activity for Activity C :

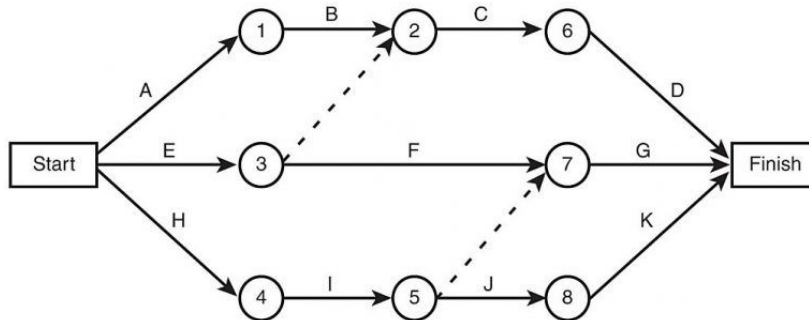

- m. Activity B
- n. Activity A
- o. Activity D
- p. Activity F

112. A Dummy Activity is the one which:

- a. Consumes time and Resources
- b. Does not Consume any time and Resources
- c. Consumes time but does not consume Resources
- d. Consume human Resources

113. Project Network Analysis helps the project Manager to:

- a. Maximize the Project Cost
- b. Prepare the Project Charter
- c. Define Project Scope
- d. Optimum Utilization of Resources

114. The value of FLOAT for any Critical Activity is:

- a. Always equal to ZERO
- b. Always equal to One
- c. Always Greater than One
- d. Always between Zero and One

115. The maximum possible time taken by an activity for completion is called as:

- a. Optimistic Time
- b. Pessimistic Time
- c. Most Likely Time
- d. Expected Time

116. The "Most Likely Time" is always:

- a. Greater than Pessimistic Time
- b. Less than Optimistic Time
- c. More than Optimistic Time but Less than Pessimistic Time
- d. Equal to the Expected Time

117. CRITICAL PATH is the _____ Path in the Project Network.

- a. Longest
- b. Shortest
- c. Less Resources consuming
- d. Independent

118. For a certain activity, the time estimates in days are: Optimistic Time=2, Most Likely Time=5 and Pessimistic Time=8. Determine the Expected Time for activity.

- a. 5 days
- b. 4 days
- c. 6 days
- d. 8 days

119. For a certain activity, the time estimates in days are: Optimistic Time=1, Most Likely Time=1 and Pessimistic Time=1. Which of the following statement is correct?

- a. Variance=1
- b. Variance=2
- c. Variance=0
- d. Variance=3

120. For a certain activity, Earliest Start Time(EST)=20, Earliest Finish Time (EFT)=45, latest Start Time (LST)= 20 and Latest Finish Time (LFT)= 45. Determine the value of TOTAL Float.

- a. Total Float=20
- b. Total Float=45
- c. Total Float=25
- d. Total Float=00

121. Which of the following is the Appropriate criterion to select any project?

- a. Net Present Value (NPV) should be positive
- b. Net Present Value (NPV) should be negative
- c. Benefit Cost Ratio (BCR) should be less than One
- d. Net Benefit Cost Ratio (NBCR) should be less than Zero

122. The demand for disposable plastic tubes for a general hospital is 300 units and 350 units for September and October month respectively. Using 200 units as the forecasted demand for September Month, calculate the forecasted demand for October month. Consider the value of Smoothing constant=0.7

- a. 270 units

- b. 300 units
- c. 350 units
- d. 200 units

123. A _____ is a set of activities which are networked in an order and aimed towards achieving the goals of a project.

- a. Project
- b. Process
- c. Project management
- d. Project cycle

124. Resources refers to

- a. Manpower
- b. Machinery
- c. Materials
- d. All of the above

125. Developing a technology is an example of

- a. Process
- b. Project
- c. Scope
- d. All of the above

126. Tool used for comparison of the proposed project to complete projects of a similar nature whose costs are known.

- a. Algorithmic model
- b. Expert judgment
- c. Top down
- d. Analogy

127. Following is (are) the component(s) of risk management

- a. Risk Assessment
- b. Risk Control
- c. Risk Ranking
- d. All of the above

128. Following are the characteristics of Project Mindset.

- a. Time, Responsiveness, Information sharing, Processes, structured planning

- b. Time, Project management, Information sharing, Processes, structured planning
- c. Time, Responsiveness, Information sharing, capability, structured planning
- d. Time, Responsiveness, Information sharing, Processes, project planning

129. The span of time within which the investment made for the project will be recovered by the net returns of the project is known as

- a. Period of return
- b. Payback period
- c. Span of return
- d. None of the above

130. Projects with _____ are preferred

- a. Lower payback period
- b. Normal payback period
- c. Higher payback period
- d. Any of the above

131. _____ on capital is called 'Cost of capital'.

- a. Lower expected return
- b. Normally expected return
- c. Higher expected return
- d. None of the above

132. The values of the future net incomes discounted by the cost of capital are called

- a. Average capital cost
- b. Discounted capital cost
- c. Net capital cost
- d. Net present values

133. Under Net present value criterion, a project is approved if

- a. Its net present value is positive
- b. The funds are unlimited
- c. Both (A) and (B)
- d. None of the above

134. The internal Rate of Return (IRR) criterion for project acceptance, under theoretically infinite funds is: accept all projects which have

- a. IRR equal to the cost of capital

- b. IRR greater than the cost of capital
- c. IRR less than the cost of capital
- d. None of the above

135. Which of the following criterion is often preferred?

- a. Net present value
- b. Profitability index
- c. Internal Rate of Return
- d. All of the above

136. The project is accepted of

- a. if the profitability index is equal to one
- b. The funds are unlimited
- c. If the profitability index is greater than one
- d. Both (B) and (C)

137. Where capital availability is unlimited and the projects are not mutually exclusive, for the same cost of capital, following criterion is used

- a. Net present value
- b. Internal Rate of Return
- c. Profitability Index
- d. Any of the above

138. A project is accepted when

- a. Net present value is greater than zero
- b. Internal Rate of Return will be greater than cost of capital
- c. Profitability index will be greater than unity
- d. Any of the above

139. With limited finance and a number of project proposals at hand, select that package of projects which has

- a. The maximum net present value
- b. Internal rate of return is greater than cost of capital
- c. Profitability index is greater than unity
- d. Any of the above

140. A project may be regarded as high-risk project when

- a. It has smaller variance of outcome but a high initial investment

- b. It has larger variance of outcome and high initial investment
- c. It has smaller variance of outcome and a low initial investment
- d. It has larger variance of outcome and low initial investment

141. Following is (are) the method(s) for adjustment of risks

- a. Risk-adjusted Discounting Rate
- b. Risk Equivalence Coefficient Method
- c. Both (A) and (B)
- d. None of the above

142. Which from the following is NOT a tangible element?

- a. Fixtures
- b. Trademarks
- c. Monetary assets
- d. Stockholder equity

143. Which from the following represents the correct project cycle?

- a. Planning→Initiating→Executing→Closing
- b. Planning→Executing→Initiating→Closing
- c. Initiating→Planning→Executing→Closing
- d. Initiating→Executing→Planning→Closing

144. The strategy used to correct resource over-allocations by balancing demand for resources and the available supply is known as

- a. resource assignment
- b. resource leveling
- c. resource splitting
- d. resource scheduling

145. According to Olivier Mesly, the 4 P's critical for the success of a project are:

- a. plan, processes, people, policy
- b. plan, processes, people, power
- c. plan, processes, potential, policy
- d. plan, processes, potential, power

146. Which of the following is not a characteristic of Projects?

- a. Have definite objectives (goals) to achieve
- b. Unique in nature
- c. Requires cross-functional teams and interdisciplinary approach
- d. Is a continuous process

147. What is a pictorial representation specifying the start and finish time for various tasks to be performed in a project on a horizontal time-scale called?

- a. Pie Chart
- b. Gantt Chart
- c. Algorithm
- d. Flow Chart

148. What is done to reduce the time of a project by investing more money?

- a. Project Crashing
- b. Project Planning
- c. Scheduling
- d. Costing

149. Net Present Value= ?

- a. Present Value (PV) of Cash Inflow- PV of Cash Outflow
- b. PV of Cash Outflow- PV of Cash Inflow
- c. Cash flow X Discounting Factor
- d. PV of Cash Inflow / PV of Cash Outflow

150. If the demand for last five months is 220, 228, 217, 219,258. What will be the demand for sixth month based on 3- monthly moving average?

- a. 221.3
- b. 231.3
- c. 239.3
- d. 246.3

151. A project will generate cash flow of Rs. 170000 after a year. What is the PresentValue of this project, if discounting rate is 14%? (PV Factor to be taken with two decimals only)

- a. 153800
- b. 149090
- c. 355200
- d. 202500

152. A probabilistic tool used where activity duration not known with certainty

- a. PERT
- b. CPM
- c. Gantt Chart
- d. None of the above

153. The longest path in the project that determines the duration of project is,
- Critical Path
 - Non-critical Path
 - Float
 - Optimistic Time
154. A project has more than one critical path. What does this mean to you?
- Risk Increases
 - Risk Decreases
 - The duration of project reduces
 - The project may cost less
155. Which of the following is not a measure for error?
- MAD
 - MAPE
 - MSE
 - MED
156. A project has a critical path of twenty-three weeks. What is the impact on the cost of the project if the management wants you to complete the project in twenty weeks?
- Increases
 - Decreases
 - Remains the same
 - Cannot be determined
157. What does Cost Performance Index (CPI) represent?
- The project is over or under budget
 - The project is ahead or behind the schedule
 - The reasons for project failure
 - None of the above
158. A company is considering Project X, which requires an initial outlay of 50 millions. The expected cash flow from these projects over four years will be 10, 20, 20, 45 millions. What is the payback period for the said project?
- 2 years
 - 3 years
 - 4 years
 - None of the above
159. Which of the following method will you use to predict the forecast for umbrellas, woolen clothes or any other product that shows seasonality?

- a. Simple Exponential Smoothing
- b. Moving Average Method
- c. Weighted Moving Average Method
- d. Trend-adjusted Exponential Smoothing

160. Crashing describes a technique to speed up a project by...

- a. ...reallocating existing resources or assigning additional resources to the project
- b. ...overlapping activities which were originally planned to be done in sequence
- c. ...reducing the number of features of the product in order to reduce development work
- d. ...reducing the duration estimates for activities to increase the pressure applied to the staff

161. A project manager reported the following earned value data: BCWS: Rs.12,400,000 BCWP: Rs. 14,500,000 ACWP: Rs. 14,500,000 What does this mean?

- a. The project is over budget and on schedule
- b. The project is under budget and on schedule
- c. The project is on budget, but behind schedule
- d. The project is on budget and ahead of schedule

162. _____ is normally not a method of ROI (return on investment) analysis.

- a. Net present value projection
- b. Sunk cost analysis
- c. Simple payback calculation
- d. Internal rate of return

163. What are the 4 stages of team development?

- a. Forming, Storming, Norming, Performing
- b. Enthusiasm, Hope, Panic, Solution
- c. Forming, Solutioning, Normalizing, Communicating
- d. Direction, Motivation, Cooperation, Collaboration

164. In which of the following phases of the project will most of the money be spent?

- a. Initiating
- b. Planning
- c. Executing
- d. Closing

165. If the completion of an activity depends on the completion of its predecessor activity, what type of dependency does this activity have on its predecessor?

- a. Start-to-Start
- b. Finish-to-Finish
- c. Start-to-Finish
- d. Finish-to-Start

166. If a project cost is 450 Millions and the project cash flow is expected to last for 8 years, what should be the minimum cash flow for break even, assuming that the cost of capital is 10%. (PV factor to be taken up to two decimals)

- a. 960.4 Million
- b. 951.4 Million
- c. 942.4 Million
- d. 964.6 Million

167. Study of impact of the change in various factors like quantity of sales, selling price, etc on the Net Present Value and viability of project is done using

- a. Break Even Analysis
- b. Simulation Analysis
- c. Sensitivity Analysis
- d. Hillier Model

168. The cash inflows and (outflows) associated with a project are as follows: Period Cash Flow At Start (120000) Year 1 40000 Year 2 50000 Year 3 60000 Residual Value 20000 The payback period for the project will be?

- a. 2 years
- b. 2 years 3 months
- c. 2 years 6 months
- d. 3 Years

169. A company sells electronic component in market at Rs. 8 per unit. The variable cost of producing one component is Rs. 4.8 per unit. The fixed amount is Rs.24000. How many units will the company have to sell in order to break-even

- a. 7000 units
- b. 7500 units
- c. 8000 units
- d. 8500 units

170. According to the time estimates made by the PERT planners, the maximum time that would be needed to complete an activity is called as _____

- e. Pessimistic time estimate
- f. Optimistic time estimate

- g. Expected time estimate
- h. The most likely time estimate

171. Activities A, B, and C are the immediate predecessors for Y activity. If the earliest finish times for the three activities are 12, 15, and 10, then the earliest start time for Y will be

- a. 10
- b. 15
- c. 12
- d. 37

172. Which of the following is used to determine ES and EF?

- a. Depends upon the project
- b. Backward Pass
- c. Forward Pass
- d. Depends upon the time schedule

173. Which of the following is not a part of Project Planning?

- a. Selection of project team
- b. Establishing a project budget
- c. Deciding project deliverable
- d. Obtaining project resources

174. When we build a house, the foundation goes in before the walls go up. These Tasks are called _____

- a. Finish-to-Start
- b. Start to Start
- c. Start-to-Finish
- d. Finish-to-Finish

175. Which of the following times is given most weightage in calculating expected time for PERT,

- a. Optimistic Time
- b. Pessimistic Time
- c. Most-likely Time
- d. Standard Time

176. Which of the following activity is undertaken immediately after feasibility study and before obtaining project resources?

- a. Project Planning

- b. Project Monitoring
- c. Project Control
- d. Project Scheduling

177. A project report at the end of 24 weeks is given below. The project is scheduled to be completed in 52 weeks and budgeted cost for 52 weeks= 125Millions ACWP=60 Millions BCWP=40 Millions BCWS=50 Millions What will be the % Cost Variance?

- a. - 50%
- b. - 40%
- c. - 30%
- d. - 20%

178. Project A has an NPV= -10 and Project B has an NPV= 10. Which of the following is true?

- a. Project A can be accepted
- b. Project A will give more returns than project B
- c. Project B can be accepted
- d. None of the above

Refer the Gantt Chart and answer the next 3 questions:

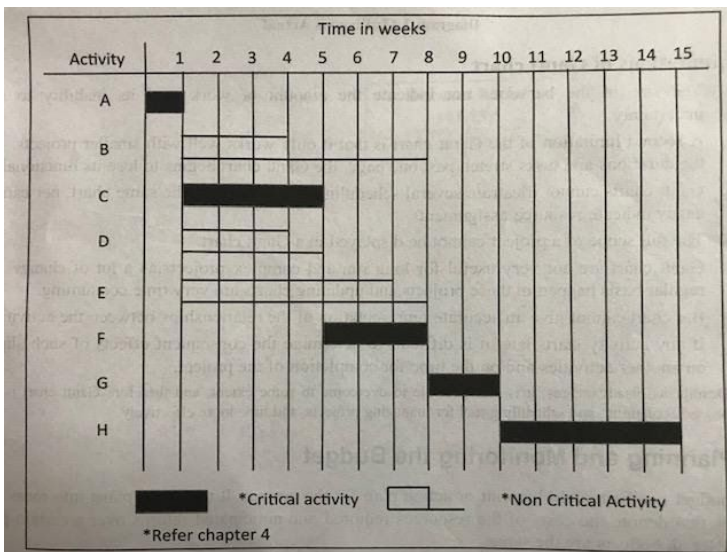

179. By how many days can you delay Activity E?

- a. 2
- b. 0
- c. 1
- d. 3

180. If you delay the duration of Activity B by 2 Days, when will it end?

- a. Week 6
- b. Week 5
- c. Week 7
- d. Week 4

181. Which of the following statements is false?

- a. By delaying Activity D by 1 day it will become critical activity
- b. Activity G can be delayed by 1 day
- c. Even if Activity B is delayed by 2 days it will not have any impact on the critical path
- d. Duration of activity C is 4 weeks

182. What type of network diagram is it?

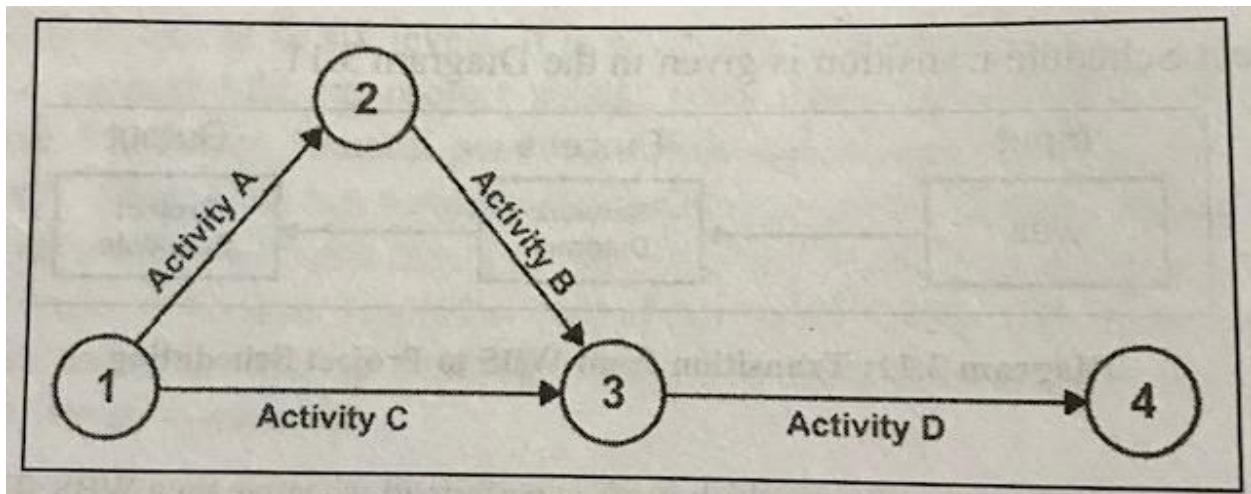

- a. AOA
- b. AON
- c. Gantt Chart
- d. None of the above

183. Gantt Charts were invented by,

- a. Henry Gantt
- b. Joseph Gantt
- c. Ishikawa
- d. None of the above

What does Schedule Performance Index (SPI) represent?

- i. The project is over or under budget
- j. The project is ahead or behind the schedule
- k. The reason for project failure
- l. None of the above

Which of the following is not a CAPEX fund?

- m. Building Purchase
- n. Purchase of Long-term Asset
- o. Operational Cost of running a product
- p. Initial Set-up costs
